

**WPLE**

## The versatile right angle planetary gearbox with lower weight and appealing cost effectiveness

The **WPLE** is a consistent continuation of the benefits offered by the Economy Line. With its compact, but powerful design, it is ideal for dynamic multiple axis systems. Our right angle gearbox features lifetime lubrication, is easy to install, all this at an unrivalled price-performance ratio.

### 1 The highest dynamics in multiple axis systems

The **WPLE** right angle gearbox delivers more than just above average performance: With 25% less weight, it outputs a particularly high torque.

### 2 Efficient and effective

As a genuine multi-talent of right angle planetary gearboxes, the **WPLE** is the specialist among the generalists – and that at an unbeatable price-performance ratio.

### 3 Flexible installation options and reliability

Fitted with lifetime lubrication, our **WPLE** right angle planetary gearbox lets you exploit restricted space to the optimal extent. It can be installed in any direction, making it the ideal choice for many applications.

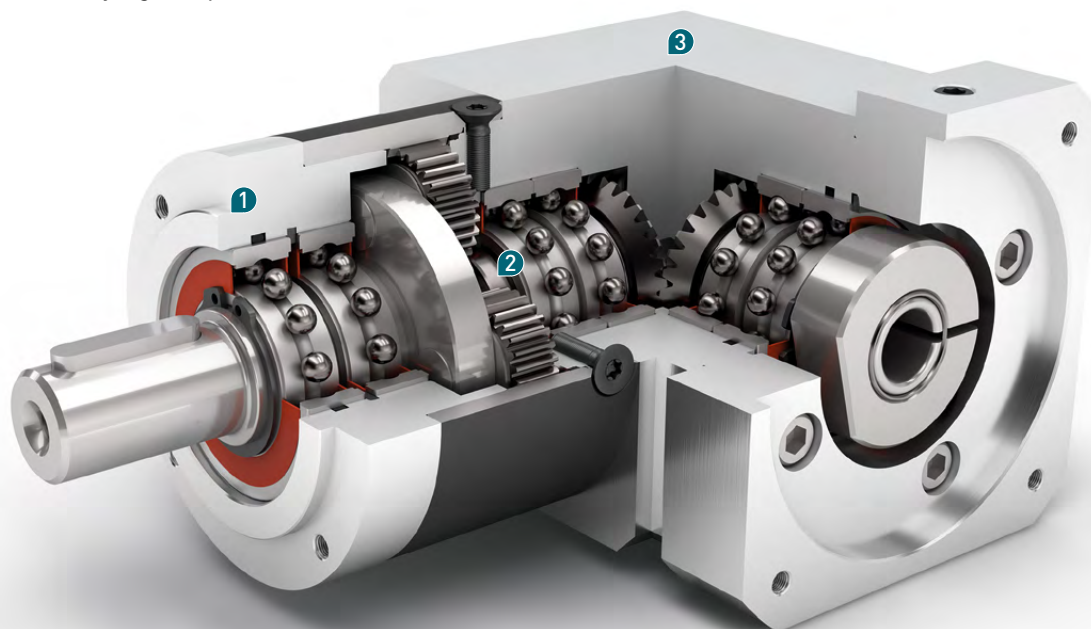

WPLE

- + Individual adaptation of the input flange to the motor
- + Lifetime lubrication for maintenance-free operation
- + Equidirectional rotation
- + Wide range of output shaft designs
- + Precise gearing
- + Wide range of ratios  $i = 3$  to  $i = 512$

Code	Gearbox characteristics			WPLE040	WPLE060	WPLE080	WPLE120	z <sup>(1)</sup>
	Service life	t <sub>L</sub>	h	20,000				
	Service life at T <sub>2N</sub> x 0.88			30,000				
	Efficiency at full load <sup>(2)</sup>	η	%	95				1
				94				2
				88				3
	Min. operating temperature	T <sub>min</sub>	°C	-25 (-13)				
	Max. operating temperature	T <sub>max</sub>	(°F)	90 (194)				
	Protection class			IP 54				
<b>S</b>	Standard lubrication			Grease				
<b>F</b>	Food grade lubrication			Grease				
<b>L</b>	Low temperature lubrication <sup>(3)</sup>			Grease				
	Installation position			Any				
<b>S</b>	Standard backlash	j <sub>t</sub>	arcmin	< 21	< 16	< 13	< 11	1
				< 25	< 18	< 15	< 13	2
				< 28	< 21	< 17	< 15	3
	Torsional stiffness <sup>(2)</sup>	c <sub>g</sub>	Nm/arcmin (lb <sub>r</sub> .in/ arcmin)	0.6 - 0.8 (5 - 7)	1.5 - 2.0 (13 - 18)	3.8 - 5.1 (34 - 45)	9.6 - 12.9 (85 - 114)	1
				0.6 - 0.8 (5 - 7)	1.6 - 2.0 (14 - 18)	4.1 - 5.1 (36 - 45)	10.4 - 12.9 (92 - 114)	2
				0.6 - 0.8 (5 - 7)	1.5 - 2.0 (13 - 18)	3.9 - 5.1 (35 - 45)	9.9 - 12.9 (88 - 114)	3
	Gearbox weight	m <sub>G</sub>	kg (lb <sub>m</sub> )	0.5 (1.1)	1.7 (3.7)	4.4 (9.7)	12 (26.5)	1
				0.6 (1.3)	1.9 (4.2)	5 (11.0)	14 (30.9)	2
				0.7 (1.5)	2.1 (4.6)	5.5 (12.1)	16 (35.3)	3
<b>S</b>	Standard surface			Housing: Steel – nitrocarburized and post-oxidized (black)				
	Running noise <sup>(4)</sup>	Q <sub>g</sub>	dB(A)	68	70	73	75	
	Max. bending moment based on the gearbox input flange <sup>(5)</sup>	M <sub>b</sub>	Nm (lb <sub>r</sub> .in)	2 (18)	5 (44)	10.5 (93)	26 (230)	
	Motor flange precision			DIN 42955-N				

Output shaft loads			WPLE040	WPLE060	WPLE080	WPLE120	z <sup>(1)</sup>
Radial force for 20,000 h <sup>(6)(7)</sup>	F <sub>r 20.000 h</sub>	N (lb <sub>r</sub> )	200 (45)	400 (90)	750 (169)	1750 (394)	
Axial force for 20,000 h <sup>(6)(7)</sup>	F <sub>a 20.000 h</sub>		200 (45)	500 (113)	1000 (225)	2500 (563)	
Radial force for 30,000 h <sup>(6)(7)</sup>	F <sub>r 30.000 h</sub>		160 (36)	340 (77)	650 (146)	1500 (338)	
Axial force for 30,000 h <sup>(6)(7)</sup>	F <sub>a 30.000 h</sub>		160 (36)	450 (101)	900 (203)	2100 (473)	
Static radial force <sup>(7)(8)</sup>	F <sub>r Stat</sub>		200 (45)	700 (158)	1250 (281)	2000 (450)	
Static axial force <sup>(7)(8)</sup>	F <sub>a Stat</sub>		240 (54)	800 (180)	1600 (360)	3800 (855)	
Tilting moment for 20,000 h <sup>(6)(8)</sup>	M <sub>K 20.000 h</sub>	Nm (lb <sub>r</sub> .in)	5 (44)	14 (124)	31 (274)	101 (894)	
Tilting moment for 30,000 h <sup>(6)(8)</sup>	M <sub>K 30.000 h</sub>		4 (35)	12 (106)	27 (239)	86 (761)	

Moment of inertia			WPLE040	WPLE060	WPLE080	WPLE120	z <sup>(1)</sup>
Mass moment of inertia <sup>(2)</sup>	J	kgcm <sup>2</sup> (lb <sub>r</sub> .in.s <sup>2</sup> 10 <sup>-4</sup> )	0.032 - 0.049 (0.283 - 0.434)	0.221 - 0.376 (1.956 - 3.328)	0.917 - 1.409 (8.115 - 12.470)	1.849 - 3.204 (16.364 - 28.355)	1
			0.032 - 0.049 (0.283 - 0.434)	0.223 - 0.378 (1.974 - 3.345)	0.931 - 1.424 (8.239 - 12.602)	1.919 - 3.397 (16.983 - 30.063)	2
			0.032 - 0.048 (0.283 - 0.425)	0.223 - 0.240 (1.974 - 2.124)	0.931 - 1.368 (8.239 - 12.107)	1.919 - 3.175 (16.983 - 28.099)	3

(1) Number of stages

(2) The ratio-dependent values can be retrieved in Tec Data Finder – www.neugart.com

(3) T<sub>min</sub> = -40°C (-40°F). Optimal operating temperature max. 50°C (122°F)

(4) Sound pressure level from 1 m, measured on input running at n<sub>1</sub>=3000 rpm no load; i=5

(5) Max. motor weight\* in kg = 0.2 x M<sub>s</sub> / motor length in m

\* with symmetrically distributed motor weight

\* with horizontal and stationary mounting

(6) These values are based on an output shaft speed of n<sub>2</sub>=100 rpm

(7) Based on center of output shaft

(8) Other (sometimes higher) values following changes to T<sub>2N</sub>, F<sub>r</sub>, F<sub>a</sub>, cycle, and service life of bearing. Application specific configuration with NCP – www.neugart.com

Output torques			WPLE040	WPLE060	WPLE080	WPLE120	i <sup>(1)</sup>	z <sup>(2)</sup>
Nominal output torque <sup>(3)(4)</sup>	T <sub>2N</sub>	Nm (lb <sub>f</sub> .in)	4.5 (40)	14 (124)	40 (354) <sup>(5)</sup>	80 (708) <sup>(5)</sup>	3	1
			6 (53)	19 (168)	53 (469) <sup>(5)</sup>	105 (929) <sup>(5)</sup>	4	
			7.5 (66)	24 (212)	67 (593) <sup>(5)</sup>	130 (1151) <sup>(5)</sup>	5	
			8.5 (75)	25 (221)	65 (575)	135 (1195)	7	
			6 (53)	18 (159)	50 (443)	120 (1062)	8	
			5 (44)	15 (133)	38 (336)	95 (841)	10	2
			16.5 (146) <sup>(5)</sup>	44 (389) <sup>(5)</sup>	130 (1151) <sup>(5)</sup>	210 (1859) <sup>(5)</sup>	9	
			20 (177) <sup>(5)</sup>	44 (389)	120 (1062) <sup>(5)</sup>	260 (2301) <sup>(5)</sup>	12	
			18 (159) <sup>(5)</sup>	44 (389)	110 (974)	230 (2036)	15	
			20 (177) <sup>(5)</sup>	44 (389)	120 (1062)	260 (2301)	16	
			20 (177) <sup>(5)</sup>	44 (389)	120 (1062)	260 (2301)	20	3
			18 (159)	40 (354)	110 (974)	230 (2036)	25	
			20 (177)	44 (389)	120 (1062)	260 (2301)	32	
			18 (159)	40 (354)	110 (974)	230 (2036)	40	
			7.5 (66)	18 (159)	50 (443)	120 (1062)	64	
			20 (177)	44 (389)	110 (974)	260 (2301)	60	3
			20 (177)	44 (389)	120 (1062)	260 (2301)	80	
			20 (177)	44 (389)	120 (1062)	260 (2301)	100	
			18 (159)	44 (389)	110 (974)	230 (2036)	120	
			20 (177)	44 (389)	120 (1062)	260 (2301)	160	
18 (159)	40 (354)	110 (974)	230 (2036)	200	3			
20 (177)	44 (389)	120 (1062)	260 (2301)	256				
18 (159)	40 (354)	110 (974)	230 (2036)	320				
7.5 (66)	18 (159)	50 (443)	120 (1062)	512				
Max. output torque <sup>(4)(6)</sup>	T <sub>2max</sub>	Nm (lb <sub>f</sub> .in)	7 (62)	22 (195)	64 (566)	128 (1133)	3	1
			10 (89)	30 (266)	85 (752)	168 (1487)	4	
			12 (106)	38 (336)	107 (947)	208 (1841)	5	
			13.5 (119)	40 (354)	104 (920)	216 (1912)	7	
			10 (89)	29 (257)	80 (708)	192 (1699)	8	
			8 (71)	24 (212)	61 (540)	152 (1345)	10	2
			26 (230)	70 (620)	208 (1841)	336 (2974)	9	
			32 (283)	70 (620)	192 (1699)	416 (3682)	12	
			29 (257)	70 (620)	176 (1558)	368 (3257)	15	
			32 (283)	70 (620)	192 (1699)	416 (3682)	16	
			32 (283)	70 (620)	192 (1699)	416 (3682)	20	3
			29 (257)	64 (566)	176 (1558)	368 (3257)	25	
			32 (283)	70 (620)	192 (1699)	416 (3682)	32	
			29 (257)	64 (566)	176 (1558)	368 (3257)	40	
			12 (106)	29 (257)	80 (708)	192 (1699)	64	
			32 (283)	70 (620)	176 (1558)	416 (3682)	60	3
			32 (283)	70 (620)	192 (1699)	416 (3682)	80	
			32 (283)	70 (620)	192 (1699)	416 (3682)	100	
			29 (257)	70 (620)	176 (1558)	368 (3257)	120	
			32 (283)	70 (620)	192 (1699)	416 (3682)	160	
29 (257)	64 (566)	176 (1558)	368 (3257)	200	3			
32 (283)	70 (620)	192 (1699)	416 (3682)	256				
29 (257)	64 (566)	176 (1558)	368 (3257)	320				
12 (106)	29 (257)	80 (708)	192 (1699)	512				

WPLE

(1) Ratios (i=n<sub>1</sub>/n<sub>2</sub>)  
 (2) Number of stages  
 (3) Application specific configuration with NCP – www.neugart.com  
 (4) Values for feather key (code "A"): for repeated load  
 (5) Different service life: 10,000 h at T<sub>2N</sub>  
 (6) 30,000 rotations of the output shaft permitted; see page 128

Output torques			WPLE040	WPLE060	WPLE080	WPLE120	i <sup>(1)</sup>	z <sup>(2)</sup>
Emergency stop torque <sup>(3)</sup>	T <sub>2Stop</sub>	Nm (lb <sub>r</sub> .in)	22.5 (199)	66 (584)	180 (1593)	360 (3186)	3	1
			28 (248)	86 (761)	240 (2124)	474 (4195)	4	
			35 (310)	80 (708)	220 (1947)	500 (4425)	5	
			26 (230)	80 (708)	178 (1575)	340 (3009)	7	
			27 (239)	80 (708)	190 (1682)	380 (3363)	8	
			25 (221)	70 (620)	170 (1505)	430 (3806)	10	
			33 (292)	88 (779)	260 (2301)	500 (4425)	9	
			40 (354)	88 (779)	240 (2124)	520 (4602)	12	
			36 (319)	88 (779)	220 (1947)	500 (4425)	15	
			40 (354)	88 (779)	240 (2124)	520 (4602)	16	
		40 (354)	88 (779)	240 (2124)	520 (4602)	20	2	
		36 (319)	80 (708)	220 (1947)	500 (4425)	25		
		40 (354)	88 (779)	240 (2124)	520 (4602)	32		
		36 (319)	80 (708)	220 (1947)	500 (4425)	40		
		27 (239)	80 (708)	190 (1682)	380 (3363)	64		
		40 (354)	88 (779)	220 (1947)	520 (4602)	60		
		40 (354)	88 (779)	240 (2124)	520 (4602)	80		
		40 (354)	88 (779)	240 (2124)	520 (4602)	100		
		36 (319)	88 (779)	220 (1947)	500 (4425)	120		
		40 (354)	88 (779)	240 (2124)	520 (4602)	160		
36 (319)	80 (708)	220 (1947)	500 (4425)	200	3			
40 (354)	88 (779)	240 (2124)	520 (4602)	256				
36 (319)	80 (708)	220 (1947)	500 (4425)	320				
27 (239)	80 (708)	190 (1682)	380 (3363)	512				

Input speeds			WPLE040	WPLE060	WPLE080	WPLE120	i <sup>(1)</sup>	z <sup>(2)</sup>
Average thermal input speed at T <sub>2N</sub> and S1 <sup>(4)(5)</sup>	n <sub>1N</sub>	rpm	5000	4500 <sup>(6)</sup>	3500 <sup>(6)</sup>	2850 <sup>(6)</sup>	3	1
			5000	4500 <sup>(6)</sup>	3550 <sup>(6)</sup>	2950 <sup>(6)</sup>	4	
			5000	4500 <sup>(6)</sup>	3600 <sup>(6)</sup>	3050 <sup>(6)</sup>	5	
			5000	4500	4000 <sup>(6)</sup>	3500 <sup>(6)</sup>	7	
			5000	4500	4000 <sup>(6)</sup>	3500 <sup>(6)</sup>	8	
			5000	4500	4000	3500	10	
			5000	4500 <sup>(6)</sup>	3250 <sup>(6)</sup>	2950 <sup>(6)</sup>	9	
			5000	4500 <sup>(6)</sup>	3850 <sup>(6)</sup>	3050 <sup>(6)</sup>	12	
			5000	4500	4000 <sup>(6)</sup>	3500 <sup>(6)</sup>	15	
			5000	4500	4000 <sup>(6)</sup>	3450 <sup>(6)</sup>	16	
		5000	4500	4000 <sup>(6)</sup>	3500 <sup>(6)</sup>	20	2	
		5000	4500	4000	3500 <sup>(6)</sup>	25		
		5000	4500	4000	3500	32		
		5000	4500	4000	3500	40		
		5000	4500	4000	3500	64		
		5000	4500	4000	3500	80		
		5000	4500	4000	3500	100		
		5000	4500	4000	3500	120		
		5000	4500	4000	3500	160		
		5000	4500	4000	3500	200		
5000	4500	4000	3500	256	3			
5000	4500	4000	3500	320				
5000	4500	4000	3500	512				
Max. mechanical input speed <sup>(4)</sup>	n <sub>1Limit</sub>	rpm	18000	13000	7000	6500		

(1) Ratios (i=n<sub>1</sub>/n<sub>2</sub>)  
 (2) Number of stages  
 (3) Permitted 1000 times  
 (4) Application-specific speed configurations with NCP – www.neugart.com  
 (5) See page 128 for the definition  
 (6) Average thermal input speed at 50% T<sub>2N</sub> and S1

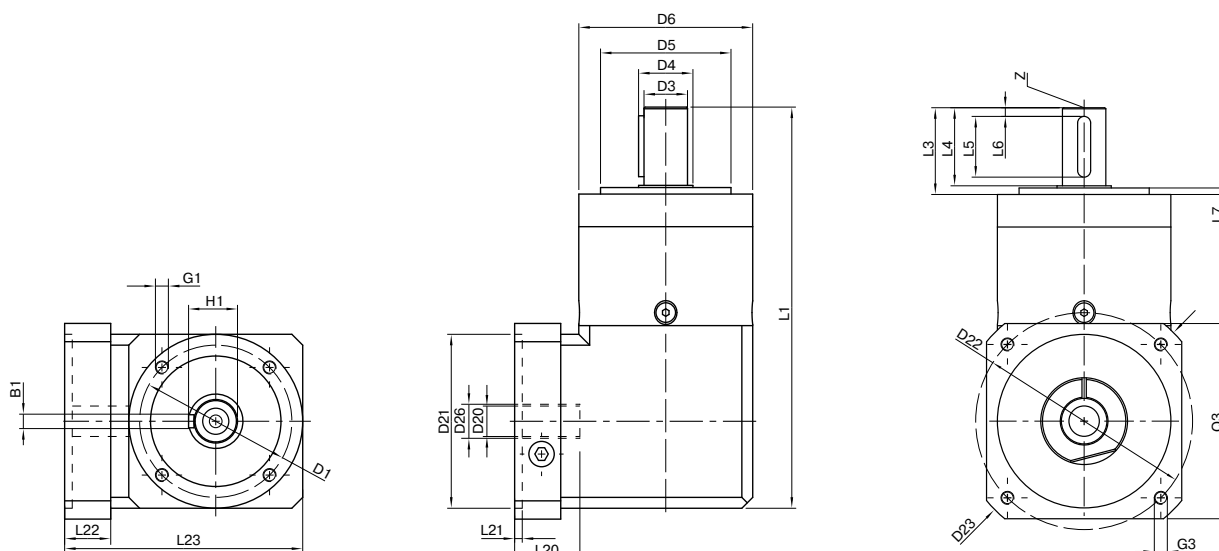

Drawing corresponds to a WPLE080 / 1-stage / output shaft with feather key / 19 mm clamping system / motor adaptation – 2-part – square universal flange / B5 flange type motor  
 All other variants can be retrieved in the Tec Data Finder at [www.neugart.com](http://www.neugart.com)

WPLE

Geometry <sup>(1)</sup>			WPLE040	WPLE060	WPLE080	WPLE120	z <sup>(2)</sup>	Code		
Pitch circle diameter output	D1		34 (1.339)	52 (2.047)	70 (2.756)	100 (3.937)				
Shaft diameter output	D3	h7	10 (0.394)	14 (0.551)	20 (0.787)	25 (0.984)				
Shaft collar output	D4		12 (0.472)	17 (0.669)	25 (0.984)	35 (1.378)				
Centering diameter output	D5	h7	26 (1.024)	40 (1.575)	60 (2.362)	80 (3.150)				
Housing diameter	D6		40 (1.575)	60 (2.362)	80 (3.150)	115 (4.528)				
Mounting thread x depth	G1	4x	M4x6	M5x8	M6x10	M10x16				
Total length	L1		110 (4.331)	147 (5.787)	184 (7.244)	249.5 (9.823)	1			
			123 (4.843)	159.5 (6.280)	201.5 (7.933)	277 (10.905)	2			
			135.5 (5.335)	172 (6.772)	219 (8.622)	304.5 (11.988)	3			
Shaft length output	L3		26 (1.024)	35 (1.378)	40 (1.575)	55 (2.165)				
Centering depth output	L7		2 (0.079)	3 (0.118)	3 (0.118)	4 (0.157)				
Min. overall height	L23		62 (2.441)	86 (3.366)	110 (4.331)	146 (5.728)				
Clamping system diameter input	D26		More information on page 117							
Motor shaft diameter j6/k6	D20		The dimensions vary with the motor/gearbox flange. The input flange geometries can be retrieved for each specific motor in Tec Data Finder at <a href="http://www.neugart.com">www.neugart.com</a>							
Max. permis. motor shaft length	L20									
Min. permis. motor shaft length										
Centering diameter input	D21									
Centering depth input	L21									
Pitch circle diameter input	D22									
Motor flange length	L22									
Diagonal dimension input	D23									
Mounting thread x depth	G3	4x								
Flange cross section input	Q3	■								
Output shaft with feather key (DIN 6885-1)			A 3x3x18	A 5x5x25	A 6x6x28	A 8x7x40				
Feather key width (DIN 6885-1)	B1		3 (0.118)	5 (0.197)	6 (0.236)	8 (0.315)		A		
Shaft height including feather key (DIN 6885-1)	H1		11.2 (0.441)	16 (0.630)	22.5 (0.886)	28 (1.102)				
Shaft length from shoulder	L4		23 (0.906)	30 (1.181)	36 (1.417)	50 (1.969)				
Feather key length	L5		18 (0.709)	25 (0.984)	28 (1.102)	40 (1.575)				
Distance from shaft end	L6		2.5 (0.098)	2.5 (0.098)	4 (0.157)	5 (0.197)				
Center hole (DIN 332, type DR)	Z		M3x9	M5x12.5	M6x16	M10x22				
Smooth output shaft										
Shaft length from shoulder	L4		23 (0.906)	30 (1.181)	36 (1.417)	50 (1.969)		B		

<sup>(1)</sup> Dimensions in mm (in)

<sup>(2)</sup> Number of stages